

# Adept ApproFlex 800



Graphical and easy to use part teaching



Touch screen user interface



Digital motion controller



Vision



## Specifications

|   |                        |
|---|------------------------|
| Maximum payload   | 0.5 kg                 |
| Maximum speed   | 1500 mm/s              |
| Repeatability   | ± 0.03 mm              |
| Four axis gantry mechanism (X, Y, Z, Theta)   |                        |
| X (1350 dimension)  | 800 mm                 |
| Y (820 dimension)   | 500 mm                 |
| Z (vertical orientation)  | 150 mm                 |
| Digital servo control-brushless motors  |                        |
| End-Effectors options   |                        |
| • Vacuum cup, pneumatic gripper or electromagnetic pad  |                        |
| Parts located by Vision system  |                        |
| • CCD FireWire 256 grey levels camera, 640 x 480 pixels.                                      |                        |
| Communication   |                        |
| • Digital Inputs/Outputs (16 inputs, 8 outputs 24VDC included; more over Field Bus)           |                        |
| • Serial RS-232,  |                        |
| • Field Bus: Modbus, FireWire.  |                        |
| Three-color Triliptical Status Indicator lamps for easy diagnostics and system status display |                        |
| Productivity  |                        |
| • Up to 40-50 parts per minute, based on part complexity (vision, gripping, etc)              |                        |
| Power supply  | 240V (16A)<br>50-60 Hz |
| Consumption   | 2KW                    |
| Facility  |                        |
| • Earthing system requirements: TT or TN  |                        |
| • IT: earth requires isolating transformer  |                        |
| Weight  | Approx. 600 kg         |

The ApproFlex product is an intelligent flexible feeding cell for all your flexible feeding challenges. This cost effective product can locate an object on the surface, identify it, pick and place it in a defined and precise position and orientation. Provides seamless and flexible solutions for such applications as, handling of bulk parts, sorting, positioning, loading of machines including a host of other applications and solves the “fast time to market” challenges for new product developments and fast product changeovers.

The ApproFlex can be compared to a smart bowl feeder with the following advantages:

- **Flexibility:** Several kinds of parts with various shapes and dimensions can be handled by the same ApproFlex
- **Versatile:** Outstanding versatility for all types of parts handling applications that incorporate all the technologies of flexible feeding. This eliminates the need to change hardware every time a part undergoes a change or becomes obsolete, including:
  - The need for dedicated tooling
  - Design and manufacturing costs
  - Provides expansion for now and the future
- **Polyvalence:** The system does not require any shape or mass criteria regarding the parts
- **Ease of use:** Simple and user-friendly configuration from a graphical and intuitive interface. Interface functionality is easy to use for all levels of personnel
- **Rapid deployment:** With its modular architecture, the ApproFlex is like a peripheral you can place with any production environment (conveyor, rotary table, specific machine, pallet, etc.)

Approflex's integrated robotic, vision and conveyor tracking provide an outstanding level of integration. The ApproFlex cell is sold ready to use as a cost effective product.

# Adept ApproFlex 800

## Target Applications:

Seamless and Flexible parts feeding technology for such applications as:

- Assembly:
    - Various automated assembling and feeding possibilities
  - Plastic molding:
    - Plastic part handling after injection for assembling, control, printing, sorting operations and insert placement
  - Screw machining:
    - Machine loading / unloading
- 
- Product control and inspection, such as bench loading
  - Automotive:
    - Assembly, handling, sorting
  - Cosmetics:
    - Assembly, handling, packaging and inspection machine loading
  - Easy part changeovers
- 

## Dimensions Adept ApproFlex (mm)

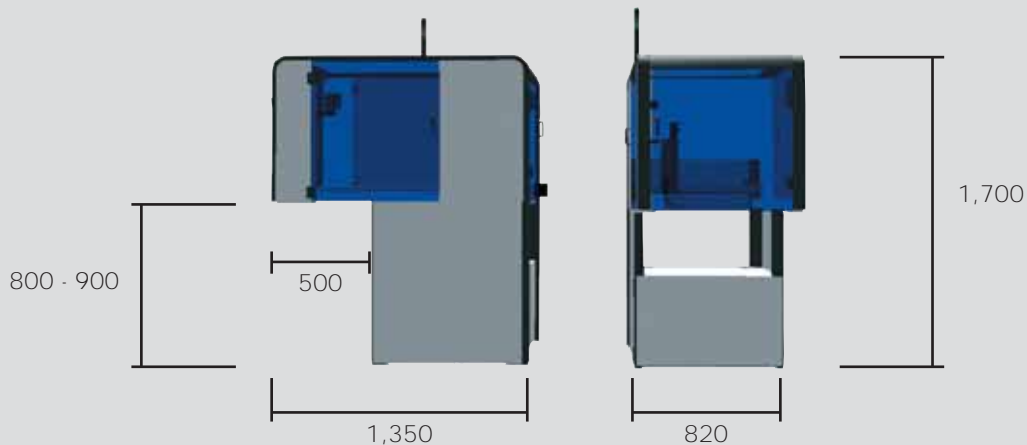

## PC-based, Graphical and Easy-to-use Part Teaching Interface

- Minimal PC configuration
  - PC Requirements:
    - 1 IEEE-1394 (FireWire) port
    - 100 MB of available hard disk space
  - The optional PC is only required for teaching new parts
  - User interface through on board touch screen
  - Part data is saved within the embedded NV RAM
  - Maximum number of parts supported by NV RAM database:
    - 15 to Approx 25
  - Possibility to swap part definition parameters files between PC and the ApproFlex
- 

## Options:

- Flexible bulk part feeders: Adept AnyFeeder
  - Re-cycling Conveyor
  - Dual part feeding
  - Modbus or FireWire Input/Output Extension Modules
  - High end Vision
  - Part flipping unit
  - Additional grippers (Pneumatic, Vacuum-cup or magnetic)
- 



Adept Technology, Inc. 3011 Triad Drive, Livermore, CA 94551

Tel: 925-245-3400 Fax: 925-960-0452 Email: info@adept.com

[www.adept.com](http://www.adept.com)

Specifications subject to change without notice.

©2008 Adept Technology, Inc. All rights reserved. Adept and the Adept logo are registered trademarks, and the Adept ApproFlex is a trademark of Adept Technology, Inc. All other trademarks are the property of their respective holders. AAFDS0208