

Adept Quattro™ s650H



Specifications

Number of Axes	4	
Payload (rated, max)	6 kg	
Working Range		
Diameter	1300 mm	
Height (std./max.)	215 mm/500 mm	
Rotation	± 60° or ± 185°	
Repeatability		
Platform	60°	185°
Position	± 0.1 mm	± 0.1 mm
Angular	± 0.042°	± 0.12°
Max. Speed	10 m/s	
Max. Acceleration (appr.)	150 m/s ²	
Robot Cycle Times, sustained (seconds)		
Payload (kg)	Std. Cycle*	Ext. Cycle**
0.1	0.30	0.46
1.0	0.36	0.47
2.0	0.37	0.52
4.0	0.41	0.58
6.0	0.43	0.61
* Adept Cycle in mm (25/305/25)		
** Extended Cycle in mm (40/700/40)		
(at 20°C ambient)		
Power Requirement (User Supplied)		
24VDC (± 10%)		
200V to 240V AC, 1-phase, 50/60Hz		
Protection		
IP 66/67 (Optional cable sealing kit available)		
Cleanroom Class 1000		
Mounting	Inverted	
Environmental Requirements		
Ambient Temperature	1 - 50 °C	
Humidity Range	5 - 90 % (non condensing)	
Weight	117 kg	
CE compliant		

The Adept Quattro is a parallel robot designed for high-speed packaging and material handling. It is the only robot in the world that features a unique four-arm with a rotational platform designed for high speeds, high acceleration and exceptional performance across the entire work envelope. Powerful embedded amplifiers and compact controls make installation easy and reduce workspace requirements. The high speed and precision of the Quattro robot make it a perfect choice for flexible and productive “one at a time” packaging, material handling, kitting and assembly applications.

Product Features and Benefits

- 4 parallel arms with rotational platform design for high speeds
- 6 kg rated payload
- High-efficiency motors deliver high performance with more torque per ampere
- Large 1300 mm work envelope
- Maximum of 500 mm Z stroke
- Embedded SmartServo controls
- High repeatability and precision
- High-resolution encoders provide high precision and superior slow-speed following
- Consistent speeds across entire work envelope increase productivity and reliability
- Ensures system reliability and high production uptime
- Enables high product mix and changeover
- Reduces integration costs
- Accelerates time to market
- Cabling and workspace savings through integrated controls and amplifiers
- Provides increased flexibility and accuracy through integrated vision guidance



Adept Quattro™ s650H

Dimensions Adept Quattro (mm)

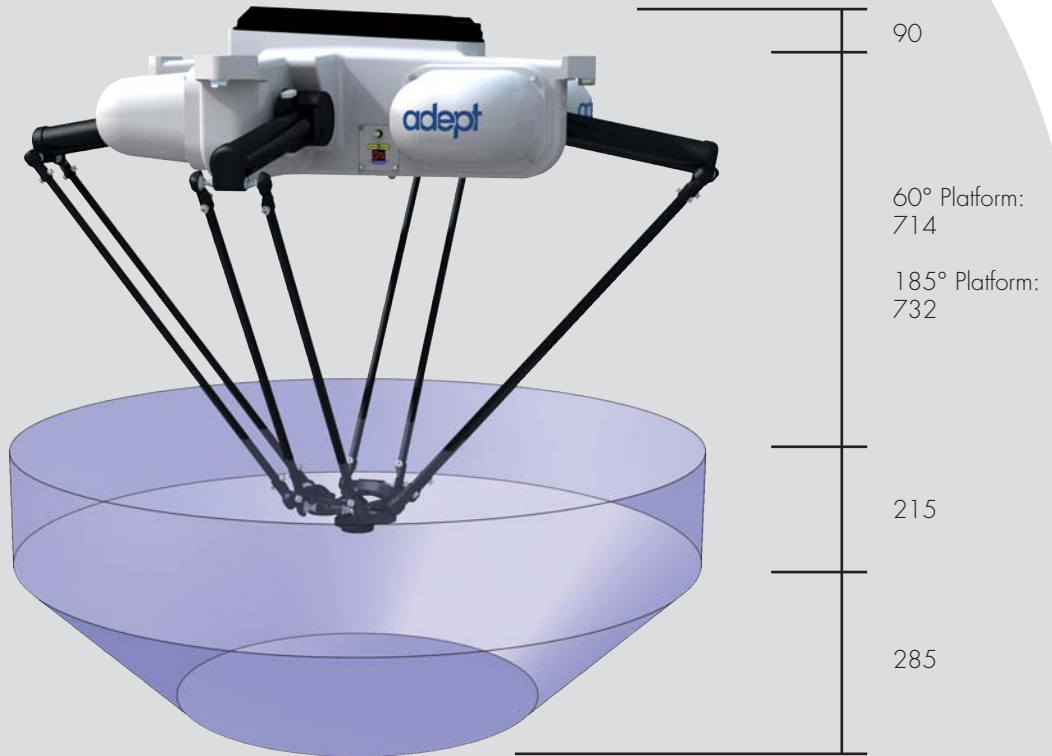

- Workspace:
 - Radius 650 mm (0 - 215 mm)
 - Radius 350 mm (215 - 500 mm)

The Adept Quattro system includes the following:

- Adept Quattro robot with AIB (Amplifiers in Base)
- Adept SmartController CX controller (with software installed)
- Front Panel with E-Stop
- AdeptWindows Software
- Ethernet TCP/IP capability
- User Documentation

The user must supply the following items:

- Power to SmartController CX and AIB
- Cell-based emergency stop wiring
- Windows™-based PC (not required at run-time)

Optional Peripherals:

- Adept DeskTop
- AdeptVision: either sAVI or AdeptSight (requires a PC for programming)
- V+ Extensions License for Conveyor Tracking
- T2 Pendant
- IP 66 Cable Seal Kit



Adept Technology, Inc. 3011 Triad Drive, Livermore, CA 94551

Tel: 925-245-3400 Fax: 925-960-0452 Email: info@adept.com

www.adept.com

Specifications subject to change without notice.

©2008 Adept Technology, Inc. All rights reserved. Adept and the Adept logo are registered trademarks, and the Adept Quattro is a trademark of Adept Technology, Inc. All other trademarks are the property of their respective holders. AQS650HDS1008